

অসম চৰকাৰ



সংস্কৃত ভাষা

GOVERNMENT OF ASSAM

Information Technology Department



ডিজিটেল অসম
DIGITAL ASSAM

**ADVANTAGE
ASSAM**

India's expressway to ASEAN

Information Technology and
Electronic Policy Assam, 2017

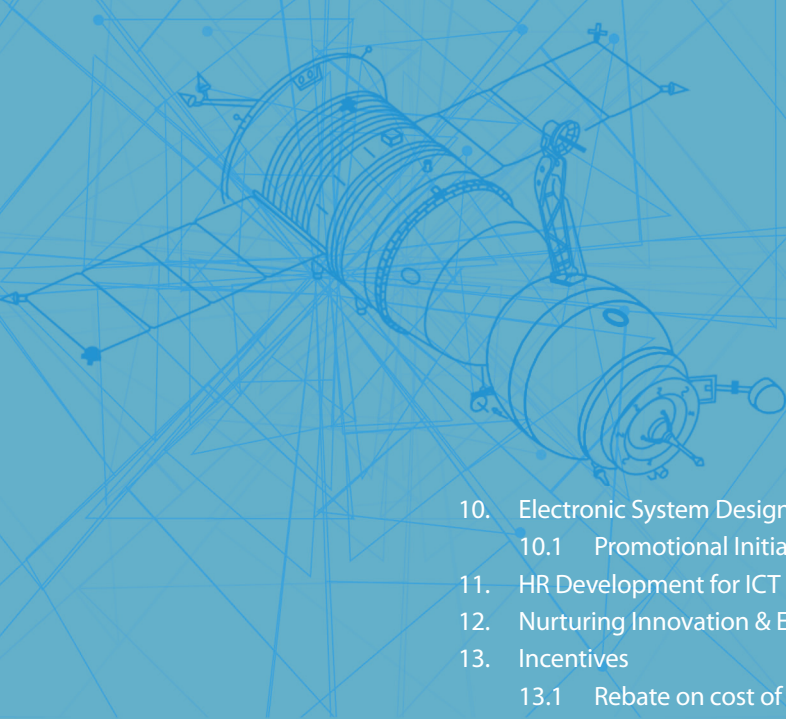





TABLE OF CONTENTS

1.	Preamble	3
2.	Vision	3
3.	Definitions	4
4.	Objectives	6
4.1	Promotion of IT/ITeS/ESDM Industry:	6
4.2	E-Services:	6
4.3	E-Governance:	6
4.4	E-Transformation:	6
5.	Competitive Advantage	7
6.	Strategies	8
6.1	E-Governance	8
6.2	Policy initiatives:	9
6.2.1	Broadband for all:	9
6.2.2	Data Sharing:	9
6.2.3	Data Security:	9
6.2.4	ESDM:	9
6.2.5	e-Waste:	9
6.2.6	ICT in Education:	9
6.2.7	Inclusiveness:	9
6.2.8	Government Process Re-engineering (GPR):	9
6.2.9	New Technologies:	10
6.3	Transparency initiatives:	10
6.3.1	E-Procurement:	10
6.4	Service Delivery initiatives:	10
7.	Digital Empowerment Initiatives	11
8.	Business Initiatives	11
9.	IT/ITeS/ESDM Park	12
9.1	Government owned IT Park:	12
9.2	Certified Private IT parks:	12



10.	Electronic System Design & Manufacturing	12
10.1	Promotional Initiatives	13
11.	HR Development for ICT	13
12.	Nurturing Innovation & Entrepreneurship	14
13.	Incentives	14
13.1	Rebate on cost of land allotted	14
13.2	Capital Subsidy	15
13.3	Registration, Stamp Duty Concession	16
13.4	Power Tariff Rebate	16
13.5	Lease Rental Subsidy	16
13.6	State Goods and Services Tax (SGST) Reimbursement	16
13.7	Incentive for Patent Assistance in ICT field	17
13.8	Special Incentives	17
13.9	Non-fiscal benefits for ITeS and Electronic/IT hardware manufacturing industries:	17
13.10	Reimbursement of Incentives:	18
14.	Investment Promotion and Implementation Support	18
14.1	Single Window Clearance	18
14.2	Policy Implementation	18
14.3	Policy Implementation Guidelines	19
14.4	Operative Period of Policy	19
14.5	Procedures for Implementation and Application	19
14.6	Eligibility Criteria for grant of incentives	19
15.	Rights of the State Government	20
ANNEXURE-I:	ABBREVIATIONS AND ACRONYMS	21
ANNEXURE-II:	LIST OF INSTITUTIONS OF HIGHER LEARNING	24
ANNEXURE-III:	BROAD CLASSIFICATION OF VERTICALS/ PRODUCTS & SERVICES COVERED FOR ELECTRONIC HARDWARE SECTOR	25
ANNEXURE-IV:	LIST OF ELIGIBLE IT ENABLED SERVICES (ITeS)	27
ANNEXURE-V:	LIST OF ADMISSIBLE ITEMS FOR FIXED CAPITAL	28



1. PREAMBLE

Assam has witnessed significant growth in the ICT sector in the past one decade, due to the proactive initiatives taken by the State Government in terms of creation of state-of-the-art physical infrastructure, provision of basic amenities such as roads, water, sewerage and power to the doorsteps of IT layouts, availability of large English speaking and technical talent pool, lower cost of operation and innovative e-Governance programmes. Today, Assam is poised on the threshold of becoming a valued destination for ICT Industry, and acknowledging this aspect, the State has decided to notify a new IT & Electronics Policy 2017 to promote Assam as one of the pioneer ICT hubs. The State desires to become a leading destination for investment in Information and Communications Technology (ICT) industry and to become a major partner in the Information Technology Economy.

Government of Assam shall endeavour to support industries in the sector by way of single window clearance, developing “Brand Assam” and incentivizing the investors.

2. VISION

The Vision of the IT & Electronics Policy 2017 is:

To transform Assam into a sustainable and innovative society of excellence in ICT with focus on enhancing the quality of governance for the benefit of common citizens through digital empowerment and deployment of emerging technology solutions in all aspects of socio-economic life, enhancing the capacity and skill sets of the new generations for employment in IT/ITeS/ESDM sector, promoting innovation and start-ups.

This Policy shall be applicable from the date of notification and shall remain in force from 1.1.2018 to 31.12.2022.

3. DEFINITIONS

- i) **Government** means the Government of Assam, unless the context otherwise specifies it to mean the Government of India or any other Government.
- ii) **Information Technology** includes Information Technology, electronics and communications, e-Governance and m-Governance initiatives, e-Commerce, m- Commerce etc.
- iii) **Information Technology industry** includes software industries and electronics/IT hardware manufacturing industries.
- iv) **IT software industry** includes IT software, IT and IT enabled Services including registered training Institutions.
- v) **IT Infrastructure companies** mean the real estate infrastructure developer(s) or a builder(s) constructing IT Office space for sale / lease or for lease-cum-sale to IT Industry / Financial Institution for the purpose of IT activities by the IT Industry defined above.
- vi) **Telecommunication companies** include Basic Telecom Service Providers (fixed), VSAT, cellular (Mobile) companies, Telecom Infrastructure companies, ISPs and any other value added services licensed by Ministry of Communication, Government of India.
- vii) **Date of commencement** of commercial operation, in respect of a product goods or services, it is the date on which commercial operations of the company has commenced for that particular operation in the State i.e., the date of the first commercial sale bill / invoice raised by the ICT company concerning a particular product, goods or services.
- viii) **Micro, Small and Medium Enterprises (MSMEs):**
 - a) **SME** means Small & Micro IT/ITES/ESDM Companies/units/Enterprises with turnover of more than Rs. 50 Lakhs and less than Rs. 10 Crores per annum.
 - b) **Mid-Scale (Medium) Enterprises:** IT/ITES/ESDM Companies/units with turnover more than Rs. 10 Crores and less than Rs. 200 Crores per annum.
- ix) **Eligible Unit** means any IT/ITeS/ESDM New unit with minimum 15 employees on its permanent payroll involved in core economic activities of the unit such as software development, business development, hardware manufacturing etc. setting up its operations in Assam during the operative period of this policy.
- x) **NEW UNIT** means an IT unit in the State, which has commenced commercial operation on or after the date on which this policy is notified.
- xi) **EXISTING UNIT** means an IT unit in the State, which is or was in commercial operation at any time prior to the date of notification of the policy.



- xii) **100% Export Oriented unit** means an IT unit in the State, which undertakes to export its entire value added goods and services subject to relaxation as permitted by the Government of India from time to time.
- xiii) **Fixed Capital** means and includes investment in plan & machinery and building connected directly with manufacturing process, including operational space, laboratory, plant & machinery, hardware, software and other fixed assets required to produce IT/ITeS/ESDM product or services and its installation cost, pre-operative expenses capitalized, electrical and such other equipment, which are directly related to operational activities.
- xiv) **Implementing Agency** means IT Department or an agency nominated by IT department for administering this policy.
- xv) **BPO operation** includes IT enabled services which are defined by Central Board of Direct Taxes (CBDT) and NASSCOM, mentioned in the Annexure –IV of the policy.
- xvi) **Start-up** means an entity incorporated or registered in India under the laws, not prior to five years from the date of notification of this policy, with audited annual turnover not more than Rs. 25 Crores in any preceding financial years working towards innovation, development, commercialisation of new products, processes and services having intellectual property and is driven by Information Technology, provided that any such entity formed by splitting up or reconstruction of a business already in existence shall not be considered a “start-up”.
- xvii) **Mega Project** means investment in fixed capital Investment above Rs.100 Crs. or generating a minimum of 1000 regular employment.
- xviii) **Core operation** means employees engaged in the main economic activities of the unit and shall exclude people employed in support services such as security guards, gardening, drivers etc.

4. OBJECTIVES

4.1 Promotion of IT/ITeS/ESDM Industry:

- i) Create enabling environment for growth of IT, ITeS and Electronics Manufacturing industries by providing attractive fiscal and non-fiscal incentives at par with other advanced states of the country.
- ii) To create opportunities for the qualified youths of the State to get meaningful employment in the IT/ITeS/ESDM sectors of the State.

4.2 E-Services:

- i) Ensure electronic delivery of services to citizens and business, across all departments, to achieve the objective of transparency and efficiency.
- ii) Enable "SMART" (Simple, Measurable, Accountable, Responsive and Transparent) governance through digital work flow and automation systems.

4.3 E-Governance:

- i) Develop core ICT infrastructure for delivery of e-services and promote the use of ICT in governance.
- ii) Provide broadband connectivity to all Government offices up to blocks/gram Panchayats/villages by 2022.
- iii) Promote and set up critical ICT infrastructure such as communication networks, IT Parks, Incubation Centers and peripheral services through Government and private partnerships.

4.4 E-Transformation:

- i) Re-engineer the government processes to suit the delivery of electronic services.
- ii) Put in place programmes and schemes in IT sector, both in terms of employment and entrepreneurship.
- iii) To undertake digital literacy program for making 25 Lakh rural citizens of the State digitally literate by 2022 and to provide computer education to every student in the State-run schools.

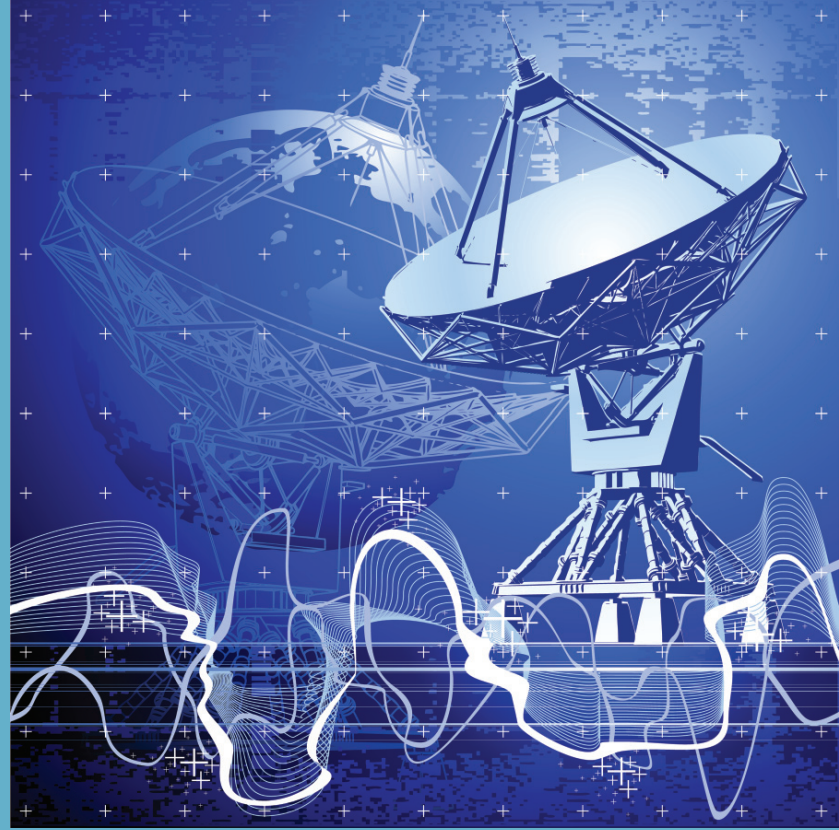

5. COMPETITIVE ADVANTAGE

- i) With regard to Technical Education, the State has one Indian Institute of Technology (IIT), one Indian Institute of Information Technology (IIIT), Nineteen Engineering Colleges/Universities (Govt. & Private Sector including NIT) offering twenty one graduate courses with an intake capacity of more than 3500 students per year. There are also eight polytechnics and twenty three industrial training institutes (ITIs) which offer specialization options in various technology disciplines. In addition, Central Institute of Plastic Engineering & Technology (CIPET) & National Tool Room offers Diploma and Certificate courses producing quality manpower for employment in the industry. Apart from above, Assam has ten (10) Universities including Central & Private Sector Universities, one specialized Agriculture University including one Open University. There are around 590 colleges at Graduate level for studies in Arts, Science, Commerce, Law etc. for under-graduate students.
- ii) Assam is the most developed State in the North-East region of India and fast emerging as economic and commercial hub for future business with South East Asian Country. The State is very well connected to rest of the country, NE states capitals and neighbouring countries. With the special focus of Government of India under Act East Policy, the State's importance for business and commerce is bound to grow further.
- iii) The State literacy rate is 73.18 percent against the national average of 74 percent as per 2011 Census, out of which male literacy figures are at 78.81 percent and female literacy figures are at 67.27 percent. Urban and Rural literacy rate is at 88.88 percent and 70.44 percent respectively. A large portion of the population in the age group of 15 to 30 years in the major towns are IT literate and skilled with good command on English language.
- iv) The Telecommunication Network is one of the fastest growing sectors in the State.

Both State and Central Government are making all efforts to further improve the connectivity in the State. The citizen and business today have access to required bandwidth on demand in most of the areas.
- v) The State Government has already started developing a state of the art IT park covering 100 acres plot of land, which is adjacent to the LGB International Airport in Guwahati. Already State is receiving encouraging response from the Investors for this IT Park.
- vi) Today, the State has a proactive, stable government with full commitment for creating a conducive atmosphere for the business to establish, expand and diversify for their own growth and as well as for strengthening the State's economy by creating employment avenues and investment opportunities.
- vii) The State is implementing necessary reform for simplifying processes and procedures for business to establish and operate their units in a transparent and hassle free manner under the Ease of Doing Business (EoDB) program. Most of the services or interactions of the business with government today are delivered through digital platform in time bound manner.

6. Strategies

6.1 E-Governance

The State Government aims to be at the highest level of maturity in e- Governance i.e. by transforming itself into a fully integrated e-Government and to become the best e- Governed State on all fronts by taking following measures:

- i) Government shall endeavour to provide all the citizen centric services including services coming under the Assam Right to Public Service (ARTPS) Act, 2012 electronically.
- ii) A minimum of 3% of total SOPD allocation shall be provisioned by all departments for e-Governance initiatives both in procurement of hardware and development of software applications. Every Department and State Government Agencies would adopt an IT plan in consultation with the IT Department for preparation of budget plan for ICT component.
- iii) Providing 24X7 delivery of services to the citizens through CSCs and other delivery channels like mobile and web etc.
- iv) All e-governance projects shall adhere to the guidelines of “Open Standards” issued by Central Government. The State Government also encourages the use of Open-Source Software to the extent possible in order to cut down unnecessary costs. Wherever proprietary software needs to be used, it should be properly justified.
- v) The Government is committed to curb software piracy and to protect the IPR of software companies and will encourage and support the use of Genuine and Legitimate Software in the State.
- vi) The Government will give high priority for ensuring Cyber Security to all e- Government ICT infrastructures as well other ICT infrastructure of the State and adopts the best practices in terms of technology and practise.
- vii) The State Govt. will leverage the efforts put in by organisations like NIC, STQC, NeGD and others in developing various e-Governance projects.
- viii) The Government shall facilitate network service providers to ensure adequate bandwidth wherever required.
- ix) The Government shall specially encourage innovative solutions designed by start-ups based in the State in e-governance arena and other technological solutions for improvement of Governance and would also frame guidelines for piloting and procurement of their services.
- x) Use of local languages and localisation shall be made a part of all e- Governance/m-governance initiatives.
- xi) A comprehensive system of impact assessment of all e-Governance initiatives and other investments made by the State Government departments in ICT projects etc. shall be done through independent agencies from time to time to evaluate the socio-economic benefits and outcome of such investment.

6.2 Policy initiatives:

6.2.1 Broadband for all:

To provide at least 15 mbps for all rural and urban households and 100 mbps for all Government offices of the State on demand at an affordable cost for providing seamless converged services like voice, data, video, IpTV, IP telephone and other value added services in a technology and service neutral environment.

In order to achieve this task, the Government has already created a special mission.

6.2.2 Data Sharing:

The Government will facilitate sharing of data across departments to establish a connected government and thereby providing citizens hassle free services.

6.2.3 Data Security:

Government will ensure highest level of security and privacy of citizens' data, security and quality audit shall be mandated in all e-Governance projects.

6.2. ESDM:

Electronic System Design and Manufacturing (ESDM) for design and manufacturing of electronic goods and items in the State would be encouraged.

6.2.5 e-Waste:

The Government affirms its commitment to environmental protection by ensuring proper e-Waste management. The disposal of obsolete ICT equipments shall be made in accordance with e-waste management policy/guidelines of Government of India.

6.2.6 ICT in Education:

Include "ICT" in the school curriculum and e-learning platforms from the post- primary to higher level to ensure that all the students of the State are digitally literate.

6.2.7 Inclusiveness:

Government's web content shall be made accessible to the differently-abled by ensuring that all Government websites comply with the W3C guidelines. All departmental websites have been standardized for easy availability of authenticated and updated information.

6.2.8 Government Process Re-engineering (GPR):

State Government will redesign the existing government processes wherever required for improvement in electronic services delivery and continuously work towards improvement of the quality of delivery through various delivery channels.

6.2.9 New Technologies:

The Government will promote the increased use of new and evolving technologies viz: Internet of Thing (IoT), supercomputing, Quantum Computing, Machine learning, Cyber security, Artificial Intelligence, Big Data, Virtual Reality, Zero fault software, 4G/5G communication to enhance the public service delivery and to ensure optimal use of resources by making Assam a preferred destination in the global IT/ITeS/ESDM sectors.

6.3 Transparency initiatives:

6.3.1 E-Procurement:

The Government will ensure a single unified end-to-end electronic platform for the procurement through PKI enabled workflows in procurement transactions to ensure transparency and efficiency in procurement in all departments. State Government notified Assam Public Procurement Act, 2017 and the e-procurement system will be further strengthened in consultation with Finance Department.

6.4 Service Delivery initiatives:

- i) Information and Services will be delivered through Standardisation of State Government Websites. The e-services shall be developed and integrated with e- forms/applications and will be made available to the citizens through a common portal and departmental portals.
- ii) Government will give priority to development of technologies for enabling local language solutions and promote the same while delivering Government services online.
- iii) Integration of existing e-governance application with that of NRC, Aadhar will be implemented in a phased manner.
- iv) Government would make provisions for "On Demand" availability of IT Infrastructure, Platforms and Common Applications using Cloud and similar technologies for the Government departments for rapid deployment of their application/s.
- v) Electronics Service delivery will be coordinated and monitored by an office, notified by the IT Department. Further, necessary guidelines for ICT project management, core ICT infrastructure sharing, use and its cyber security aspects would be initiated by the IT Department.

7. Digital Empowerment Initiatives

- i) Government of Assam aims to make one person from each rural household digitally literate within the policy period.
- ii) Government of Assam encourages adoption and use of digital payments by all citizens, merchants, traders etc. in all sectors and develop applications towards this end.
- iii) Government of Assam will try to ensure safe cyberspace for all the citizens of the state.
- iv) Specific ICT Programs will be undertaken for students, women, and specially abled citizens of the state.
- v) Government will strive to assist needy organizations by providing ICT equipment and accessories.
- vi) Government will setup an Integrated Government Call Centre (IGCC) to enable the citizens to interact with the Government for accessing various services and to expedite grievance redressal. It will also act as a centralized help desk providing the citizens with guidance/information on various services and schemes offered by the Government.



Everything is
just a click away



8. Business Initiatives

- i) Thrust will be given for creation and improvement of civil infrastructure, connectivity among IT Hubs and ancillary facilities. IT Parks, High tech cities, Research and Innovation hubs for Start-ups, Incubators and accelerators, ESDM clusters, Prototyping, Testing and quality labs, High Performance & Supercomputing infrastructure, Data Centres, Business Process Management (BPM), Centres of Excellence etc.
- ii) Focus shall be on creating green, energy efficient and climate friendly environments and IT spaces with innovation and renewable technologies (solar and wind) using reduce, reuse and recycle principle through smart sensing and other environmental safeguards including e-waste management.
- iii) The Government will proactively market through media campaign, road shows, conclaves, trade fairs and events with specific focus in the international and national forum to promote the “Digital Assam”.
- iv) The Government wants to promote the growth of micro IT firms at grass root level for creation of employment and innovation at village level. Necessary mentoring mechanism will be set up to guide the people in setting up small scale IT firms and handhold them so that it will encourage social entrepreneurship.

9. IT/ITeS/ESDM Park

9.1 Government owned IT Park:

- i) Government of Assam will develop a world class IT Park near Guwahati International Airport over a 100 acres of land. This park is in close vicinity of Indian Institute of Information Technology, Guwahati (IIITG) and Software Technology Park of India (STPI) and Indian Institute of Technology (IITG), Guwahati. Further, two more IT parks at Dibrugarh and Silchar will also be developed by the State Govt. for attracting investment in the IT/ITeS/ESDM sector.
- ii) The Government under this policy shall allot space in the IT Park/s at a concessional rate on long term lease basis to the prospective investors. The rates will be notified by Govt. of Assam.
- iii) The Government at its own cost will create basic infrastructure for amenities like electricity, water, and sewerage treatment etc. in the IT Park for utilization of these facilities by the occupants in the IT Park.

9.2 Certified Private IT parks:

- i) In order to increase the availability of IT infrastructure, the Government shall promote IT Parks in the Private Sector (Private IT Parks) outside the Government owned IT parks.
- ii) The Government shall frame the guidelines and standards for Private IT Park certification.
- iii) Private IT Parks that meet the certification shall be governed by the same set of industry enabling regulations that are applicable to Government owned IT Parks, unless otherwise specified.

10. Electronic System Design & Manufacturing

Electronic System Design and Manufacturing (ESDM) is the fastest growing segment of the Information and Communications Technology (ICT) sector.

The State Government has taken a holistic view of the challenges and fiscal disabilities faced by the ESDM industry and these are addressed using a combination of promotional initiatives, post-performance incentives, fiscal measures, capital subsidies and other capacity building measures.

Government of Assam hereby outlines the following Promotional initiatives under this Policy, which will enable the State to be a leading contributor in India's ESDM sector and make the State a preferred destination for investments in ESDM.

10.1 Promotional Initiatives

Preferential Market Access shall be given to “Assam ESDM Companies” (Make in Assam) for the ESDM products procured by all Government Departments of Assam and their agencies. The year wise PMA and value addition thresholds for each product shall be in line with the National Electronics Policy and National Telecom Policy.

- i) For the purpose of becoming eligible under the PMA, domestically Manufactured Electronic products are those products that are manufactured by Companies registered and established in Assam and engaged in manufacturing, including contract manufacturers, but excluding traders. It should meet the percentage of domestic value addition in terms of Bill of Material (BOM) of minimum 50%.
- ii) The establishment of a free trade & warehousing zone (FTWZ) for Raw Materials, Components, Consumables, Parts and packing Materials required for Electronics Hardware manufacturing will be suitably facilitated in the State for easy access to input/raw material.
- iii) Government of Assam will set up ESDM innovation centres that will provide complete infrastructure to entrepreneurs and companies who want to take their product concept and implement a working prototype. Such innovation centres will have all the requisite design tools such as VLSI design tools, prototype development facilities, testing facilities, characterization labs, compliance and certifications labs along with requisite manpower and component stocks.

11. HR Development for ICT

Human resource constitutes to be the single most important resource in the IT industry. The linear growth of IT industry over the last 3 decades created a huge demand for highly skilled manpower and demand-supply gap. This has also resulted in reduced employability of fresh graduates as well.

- i) IT Department will facilitate skill development of local youths of the State for employability in the IT/ITeS/ ESDM units.
- ii) IT Department under this policy will create an Innovation Fund of Rs. 3 Cores per annum to foster research in ICT and Electronics in the institutions of higher learning in the State. Detail guidelines will be issued by the IT Department.



12. Nurturing Innovation & Entrepreneurship

- i) Government proposes to establish an “Innovation Zone” in Institutions of higher learning, focusing on specific technology verticals viz. Telecom, Gaming, IoT, VLSI, Robotics, 3D Printing, and Business Analytics etc. The Innovation Zone shall have the entire spectrum of private partner networks and will create innovation and entrepreneur zones. This Zone shall have all Technology Business Incubation facilities like furnished space, mentoring support, networking opportunity, Lab Facility and Innovation and Entrepreneurship Development Centres (IEDC).
- ii) Start-ups may be allowed to self-certify, to facilitate compliance with the Labour Laws. The Labour Laws to be covered under this are:
 - a) The Industrial Disputes Act, 1947 b) The Trade Unions Act, 1926
 - c) The Building and Other Constructions Workers’ (Regulation of Employment and Conditions of Service) Act, 1996
 - d) The Industrial Employment (Standing Orders) Act, 1946
 - e) The Inter-State Migrant Workmen (Regulation of Employment and Conditions of Service) Act, 1979
 - f) The Payment of Gratuity Act, 1972
 - g) The Contract Labour (Regulation and Abolition) Act, 1970
 - h) The Employees' Provident Funds and Miscellaneous Provisions Act, 1952
 - i) The Employees' State Insurance Act, 1948
 - j) The provision of the Apprentices Act, 1961

13. Incentives

The following incentives will be provided to all eligible IT/ITeS/ESDM units set up in the State under this policy.

13.1 Rebate on cost of land allotted

IT/ITeS/ESDM Units set up inside the notified IT Parks

IT/ITeS/ESDM units set up in the IT Parks will be allotted land at a rebate of 25% on the notified rate of Industries and Commerce Department, Government of Assam for Industrial park located in the same area/ district. Detailed guidelines will be issued by the Information Technology Department.

IT/ITeS/ESDM Units set up outside the notified IT Parks

IT/ITeS/ESDM units set up outside the notified IT Parks will be eligible for 50% reimbursement of the cost of the land as per the notified circle rate, subject to an upper ceiling of Rs.5 Crores. The incentive will be provided after the start of commercial operation within two years from the possession of land. Detailed guidelines will be issued by IT department.

Note-

- a) Maximum 25 acres of land will be allotted for projects in the IT Park. This incentive will be provided, subject to a condition of minimum investment of Rs.4 Crores per acre. In case of investment of more than Rs.100 Crores, allotment of land will be decided on case-to-case basis.
- b) Employees engaged in core operation means the number of persons employed for the main economic activity of the unit and shall exclude persons employed in support services such as security guards, gardening, drivers etc.

13.2 Capital Subsidy

- i) New ITeS units set up in the State will be provided capital support of Rs.1,20,000/- per seat incurred on the admissible items (the detailed list of admissible items is enumerated in Annexure-V) with an upper ceiling of Rs.30 Crores. IT Department will issue detailed guidelines later.
- ii) Existing BPO units operating in the State under the North East BPO Promotion Scheme (NEBPS) of Government of India will be provided additional 30% capital support on the quantum of capital support provided under the NEBPS, subject to satisfactory operation of the unit as certified by the Software Technology Park of India (STPI), Government of India, the nodal agency for the NEBPS.
- iii) New IT units set up in the State will be provided capital support of Rs. 1,50,000/- per employee engaged in core operations, incurred on the admissible items (the detailed list of admissible items and the detailed guidelines will be issued by the IT Department separately) with an upper ceiling of Rs.30 Crores.
- iv) Units engaged with research and development in emerging technologies in electronic and IT sector will be provided capital support of Rs. 2,50,000/- per employee engaged in core operations, incurred on admissible items (the detailed list of admissible items and detailed guidelines will be issued by the IT Department separately) with an upper ceiling of Rs. 20 Crores .

Note-

1. ITeS units with a minimum of 100 seats capacity at one location will be eligible for this incentive.
2. IT units with a minimum of 100 employees engaged in core operations at one location will be eligible for this incentive.
3. The number of people employed in BPO should be at least 1.5 times the number of the seats will be eligible for this incentive.
4. Research and Development units with a minimum of 50 people engaged in core operations in one location will be eligible for this incentive.

13.3 Registration, Stamp Duty Concession

- i) IT/ITeS/ESDM park developers will be eligible for 100% reimbursement of Stamp Duty, Registration Fee and Conversion fee paid on sale, lease and transfer of property fees for developing IT/ITeS/ESDM Park for the first transaction.
- ii) IT/ITeS/ESDM units will be eligible for 100% reimbursement of the Stamp Duty, Transfer Duty and Registration fee paid on sale, lease and transfer of property fees on the first transaction with respect to that property. (First 50 units will be considered for this incentive).

13.4 Power Tariff Rebate

- i) Eligible IT/ITeS units after coming into commercial operations will be given power tariff rebate at the rate of Rs.3/- per unit in the billed amount of the utility, on reimbursement basis for a period of 5 years with an upper ceiling of Rs.10 lakhs per annum. (First 50 units will be considered for this incentive).
- ii) Eligible ESDM unit after coming into commercial operations will be given rebate at the rate of Rs.6/- per unit in the billed amount of the utility, on reimbursement basis for a period of 5 years with an upper ceiling of Rs.20 lakhs per annum. (First 25 units will be considered for this incentive).
- iii) The innovation and business incubation centre in the IT and ESDM sector will be eligible for 50% reimbursement on the billed amount of the utility, on reimbursement basis with an upper ceiling of Rs. 6 lakhs / year. (First 5 units will be considered for this incentive).

Note:

Above assistance will be available to eligible units who have purchased power only from the State electricity distribution companies or their power distribution licensees.

13.5 Lease Rental Subsidy

IT/ITeS/ ESDM Units

IT/ITeS units taking rental space for setting up their new business units will be provided lease rental incentive of Rs.10,000/-per employee in core operations per annum, subject to creation of employment of minimum 50 people. The upper ceiling limit for this incentive will be Rs. 10 lakhs per unit per annum and this will be provided for 3 years.

13.6 State Goods and Services Tax (SGST) Reimbursement

IT/ITeS units are presently not covered for SGST reimbursement under the existing Industrial policy. IT/ITeS units shall now be provided SGST reimbursement as per the Industrial Policy of the State Government.

13.7 Incentive for Patent Assistance in ICT field

- (a) Assistance for filling patents would be provided as follows –
 - i. For Domestic patents- 50% assistance with an upper ceiling of Rs.2 lakhs/patent with a cap of Rs.10 Lakhs/ unit, once in 2 years.
 - ii. For International patents- 50% assistance with an upper ceiling of Rs.5 lakhs/ patent with a cap of Rs. 25 Lakhs/ Unit, once in 3 years.
- (b) This reimbursement shall be payable after the patent has been granted.

Note: The assistance will cover filing fees, attorney fees, search fees, maintenance fees.

13.8 Special Incentives

- (a) **Specially abled:** Special one-time incentive of Rs.10,000/- per employee engaged in core operations belonging to specially abled category and subject to an upper ceiling of Rs. 3 lakhs per unit will be provided subject to the condition that the employee has been continuously employed for 3 years and subject to other conditions as laid down by the IT Department.
- (b) **E-Waste Management:** E-Waste management units will be provided 40% incentive on fixed capital investment to set-up exclusive E-Waste management unit involving collection, disposal, recycle, subject to an upper ceiling of Rs. 4 Crores per unit and offering regular employment to minimum 75 persons. (First 3 units will be considered for this incentive).
- (c) **Production Incentives for AVGC Sector:** Animation films completely produced (100%) in the State will be given 50% of cost of production of a film for a maximum of 5 films per unit in a year, subject to a ceiling of total Rs.20 lakhs per annum. In order to be eligible for the incentive, the AVGC unit should have permanent infrastructural set-up in the state and should fulfil conditions to be issued by IT Department, Government of Assam.

13.9 Non-fiscal benefits for ITeS and Electronic/IT hardware manufacturing industries:

In addition to the benefits provided to IT Industries, the following non-fiscal benefits shall be provided for IT enabled services and Electronic/IT hardware manufacturing industries:-

- i) IT/ITeS/ESDM units may be granted exemption from the provisions of the Assam Shops and Establishment Act, 1971 relating to the hours of business and weekly closure.
- ii) General permission for three shift operations with women working in the night for IT/ITES units may be granted.
- iii) IT/ITeS units and non-hazardous hardware manufacturing industry may be notified as an essential service under Assam Essential Service Maintenance Act, 1980.

13.10 Reimbursement of Incentives:

- I. Guidelines for reimbursement of Incentives shall be issued by IT department, Govt of Assam.
- II. Any IT/ITeS/ESDM/AVGC/E-Waste Management unit cannot claim the similar incentive under different policies/schemes of the State.
- III. IT/ITeS/ESDM/AVGC/E-Waste Management units availing the benefit under this policy shall have to ensure minimum 5 years of commercial operations, after it avails any incentive under this policy.

14. Investment Promotion and Implementation Support

14.1 Single Window Clearance

The role of the Government of Assam will primarily be that of a facilitator.

- i) An empowered "Single Window Clearance Mechanism" will be set up and operationalized for granting approvals and clearances for establishing new IT/ITeS/ESDM/AVGC/E-Waste Management Units in the State.
- ii) The Directorate of IT, Electronics & Communication will act as the implementing agency for handholding and providing effective liaising with various Government departments/ agencies/ bodies.
- iii) All proposals for investment received under this policy shall be processed and approved by the State Single Window setup under Assam Bureau of Investment Promotion (ABIP).

14.2 Policy Implementation

- i) The Directorate of IT, Electronics & Communication will implement this policy.
- ii) The State Government will constitute an Empowered Committee under the Chairmanship of Chief Secretary with other departmental representatives and experts for evaluating proposals and granting approvals for eligible assistance to applicants under this policy.
- iii) To act as a single point interface, the State Government will appoint Competent Authority(s) for receiving and processing applications for Government.
- iv) Any eligible IT/ITeS/ESDM/AVGC/E-Waste Management unit or IT/ESDM Park will have the option of availing same incentive either under this Policy or any other Polices of Government of Assam in force.
- v) Any issue of interpretation of this policy will be dealt with by the IT Department and the decision of IT department shall be final.

14.3 Policy Implementation Guidelines

A set of guidelines including application forms and procedures for getting various incentives will be issued separately. The guidelines shall include definite time frame for sanction and disbursement of the declared incentives, to avoid inordinate delay and lay down the mechanism to recover any incentives, if drawn irregularly or fraudulently.

14.4 Operative Period of Policy

This Policy shall come into force with effect from the date of notification of the policy and shall remain in force for a period of five years from 01.01.2018 to 31.12.2022 or till the declaration of a new or revised Policy, whichever is earlier. Only those IT/ITeS/ESDM units or IT/ITeS Parks which commence operations either during the operative period of this policy or having applied for assistance under this policy during the operative period, within one year from coming to an end of this policy, shall be eligible for incentives.

14.5 Procedures for Implementation and Application

- i) The applications for issuance of eligibility Certificate and claims for concessions and incentives shall be submitted to the notified office (s).
- ii) The applications for issuance of Eligibility Certificate shall be made as per prescribed format.
- iii) Claims for concessions and subsidies shall be submitted as per prescribed format.
- iv) Separate guidelines for issuance of Eligibility Certificate & Submission of claims for incentives would be issued.

14.6 Eligibility Criteria for grant of incentives

- i) In order to avail the concessions and incentives, the concerned unit shall have to obtain an Eligibility Certificate.
- ii) No right or claim for any Incentives under the scheme shall be deemed to have been conferred by the scheme merely by virtue, of the fact that the unit has fulfilled on its part the conditions of the scheme.
- iii) The incentives under the scheme cannot be claimed unless the unit has complied with stipulations/ conditions of the Eligibility Certificate.
- iv) The decision of the implementing agency, subject to such direction as Government may issue from time-to-time in this regard shall be final.

15. Rights of the State Government

- i) The State Government reserves the right to amend any provision(s) including amendment or withdrawal of any of the incentives/concessions as and when necessary for development of ICT Industries and in the interest of the general people of the State from time to time under the provision of this Policy.
- ii) The State Government reserves the right to review the matter regarding sanction / disbursement of incentives to the eligible IT/ITeS/ESDM/AVGC/E-Waste Management unit(s) at any point in time whenever the government feels appropriate and in this connection, the State Government's decision shall be final and binding.
- iii) The State Government reserves the right to make/amend the necessary rules for implementation of this policy as and when required.
- iv) The decision of the IT Department, Government of Assam, as regards interpretation of this policy shall be final.
- v) The IT Department reserves the right to enact and notify any other policy or policies as deemed fit for the development of IT/ITeS sector of the State.



ANNEXURE-I: Abbreviations and Acronyms

For the purpose of this Policy, the following abbreviations and acronyms have been used

ABBREVIATION	FULL FORM/NAME
AIIL	AMTRON Informatics (India) Limited
AMTRON	Assam Electronics Development Corporation Ltd.
ARTPS	Assam Right To Public Services
ASWAN	Assam State Wide Area Network
AVGC	Animation, Visual effects, Gaming and Comic sector
BPO	Business Process Outsourcing
BSNL	Bharat Sanchar Nigam Limited
CII	Confederation of Indian Industries
CIPET	Central Institute of Plastic Engineering & Technology
CMMi	Capability Maturity Model Integration
CSC	Common Services Center
eSCM	e-Sourcing Capability Model
ESDM	Electronic System Design and Manufacturing
EMC	Electronic Manufacturing Cluster
EOU	Export Oriented Unit
FAR	Floor Area Ratio
FINER	Federation of Industries in NE Region (of India)
FSI	Floor to Space Index
G2B	Government to Business
G2C	Government to Citizen
G2G	Government to Government

ABBREVIATION	FULL FORM/NAME
GoA	Government of Assam
GSDP	Gross State Domestic Product
GoI	Government of India
GST	Goods and Services Tax
ICT	Information and Communication Technology
IEDC	Innovation and Entrepreneurship Development Centre
IIT	Indian Institute of Technology
IIIT	Indian Institute of Information Technology
IS	Information System
ITI	Industrial Training Institute
ISO	International Organization for Standardization
ISP	Internet Service Provider
IT	Information Technology
ITeS	Information Technology Enabled Services
KPO	Knowledge Process Outsourcing
MAIT	Manufacturers' Association of Information Technology
MCIT	Ministry of Communication & Information Technology
MDP	Manpower Development Programme
MMP	Mission Mode Project
MSME	Micro, Small & Medium Enterprises
NASSCOM	National Association of Software and Services Companies
NEDFi	North East Development Finance Corporation Ltd.(GoI)
NeGP	National e-Governance Plan
NIC	National Informatics Centre
NISG	National Institute for Smart Governance

ABBREVIATION	FULL FORM/NAME
NIT	National Institute of Technology
NPR	National Population Register
NRC	National Register of Citizens
OFC	Optical Fibre Cable
PKI	Public Key Infrastructure
PPP	Public Private Partnership
QAI	Quality Assurance Institute (Orlando, USA)
SDC	State Data Center
SEI	Software Engineering Institute(Carnegie Mellon)
SEMA	Software Engineering Measurement and Analysis
SME	Small and Medium Enterprise
STP/STPI	Software Technology Park (of India)
SW AN	State Wide Area Network
UID	Unique Identification
VLSI	Very Large Scale Integration
VSAT	Very Small Aperture Terminal
W3C	World Wide Web Consortium
WCAG	Web Content Accessibility Guidelines
Wi-Fi	Wireless Fidelity–a local area wireless Technology

ANNEXURE-II: List of Institutions of Higher Learning

- North East Institute of Science & Technology , Jorhat
- Indian Institute of Information Technology, Guwahati
- Indian Institute of Technology, Guwahati
- Toklai Experimental Tea Research Centre, Jorhat
- Central Institute for Plastic Engineering Technology (CIPET), Guwahati
- Tool Room Training Centre, Amingaon , Guwahati
- Sualkuchi Institute of Fashion Technology, Sualkuchi
- Indian Institute of Entrepreneurship (IIE), Guwahati
- Assam Science & Technology University, Guwahati
- Standardization Testing and Quality Certification (STQC),Guwahati
- Assam Agriculture University, Jorhat
- Gauhati University, Guwahati
- Tezpur University (Central University), Sonitpur
- Dibrugarh University, Dibrugarh
- Assam University (Central University), Silchar
- Central Institute of Technology (CIT), Kokrajhar
- Boroland University, Kokrajhar
- Kaziranga University, Jorhat (Private university)
- Don Bosco University , Guwahati (Private university)
- Jorhat Engineering College, Jorhat
- Assam Engineering College, Guwahati
- National Institute of Technology, Silchar

ANNEXURE–III: Broad Classification of Verticals/ Products & Services Covered for Electronic Hardware Sector

Sl.No.	Particulars
1	Electronics Manufacturing Services
2	Fabless Companies providing services related to manufacture of sub-assemblies and parts including integration services to the Original Equipment Manufacturers(OEMs)
3	Electronic Gaming and Electronic Toys etc.
4	Telecommunication Equipment and Cellular infrastructure equipment including Base stations, transceivers and associated systems etc.
5	Mobile phones, Landline phones, Fixed wireless terminal and Fixed cellular terminals, Telephone answering machines etc. Cable & DTH Set top box etc.
6	Computing devices like Laptops, Desktops, Servers, Storage Media and Tablet PCs etc.
7	Computer peripherals such as Printer, Mouse, Webcam, Keyboards, Speakers etc.
8	Medical Electronics
9	Industrial Electronics
10	Automotive Electronics
11	Avionics and Naval/Maritime Equipment
12	Atomic Electronics
13	Power Electronics, Grid connecting equipment etc.
14	Consumer Electronics, including Personal Media, Music Players, CD&DVD players etc.
15	Communication and Networking devices, Routers, Modems, Devices related to “Internet of things” etc.
16	Strategic electronics including assembly and component
17	Homeland Security devices
18	Biometric electronic equipment
19	Camera and Imaging Equipment
20	e-Waste Recycling equipment and process
21	Electronic Testing and measuring instruments, Weighing instruments and microprocessors/controllers and electronic displays etc.
22	Memory and Memory Devices
23	Office Automation equipment, like Scanner, printers etc.
24	Power backup/ management systems including Invertors SMPS
25	Electronic ballasts, Electronic energy meters, other electronic Meters Electronic transformers. Chocks, CILs, Inductors, Electronically-operated vending machines, ATM Machines etc.

Sl.No.	Particulars
26	Electronic active/passive components
27	PCB, its design and manufacturing ecosystem
28	R&D, Prototyping, Testing and Certification
29	Nano Electronics
30	Electronic teaching aids, education equipment etc.
31	Lighting Applications, intermediaries and LED products
32	Liquid crystal devices, Electronic display devices including Flat panel display devices etc.
33	Traffic control equipment
34	Electronic equipment for Railways, signalling, interlocking systems for railways etc.
35	Software services for electronic devices
36	Solar photo voltaic cell/modules and panels, systems/devices, Solar lanterns/lamps
37	Space application for satellites etc.
38	Electronic Accessories of various products including mobile phones, automotive, communication devices, etc., power adaptors/ chargers, Home electronic fixtures like door locking system, door closers, etc., Biometric readers, Smartcard readers/writers, RFID readers/writer, RFID tags & Smartcards, turnstiles, Electronically-controlled boom barriers etc.

Note:

- Entire value chain of all electronics verticals/products covered under National Policy on Electronics and related notifications issued by Government of India are covered under this policy.
- Value chain includes conception of a Product Idea, Innovation, R&D, Product Design, Components, Assembly, Testing and Fabrication.
- In case any Vertical/Products/Services are not mentioned/ covered above, same may be referred to a high level committee to be constituted by the IT Department for necessary recommendation to the State Government.

ANNEXURE–IV: List of Eligible IT Enabled Services (ITeS)

As per Central Board of Direct Taxes (CBDT) notification No. 890E dated 26.9.2000, the list of eligible IT enabled services considered in NEBPS are as under:

- i) Back office operations
- ii) Call centres
- iii) Content Development or Animation
- iv) Data Processing
- v) Geographic information System Services
- vi) Human Resource Services
- vii) Insurance Claim processing
- viii) Legal Databases
- ix) Medical Transcription
- x) Payroll
- xi) Remote Maintenance
- xii) Revenue Accounting
- xiii) Support Centres
- xiv) Website services

As per NASSCOM, BPO includes following processes that may be IT-enabled and which do not necessitate on-shore presence and are hence, offshore-able:

Customer Interaction & Support (CIS) - CIS includes all forms of IT-enabled customer contact; inbound or outbound, voice or non-voice based support used to provide customer services, sales and marketing, technical support and help desk services.

Finance & Accounting (F&A) - F&A includes activities such as general accounting, transaction management (account receivables and payables management), corporate finance (e.g. treasury and risk management, and tax management); compliance management and statutory reporting etc.

Horizontal-specific BPM services - Services that are reasonably similar across industries. Horizontal BPM services include Customer Interaction and Support (CIS), Finance and Accounting (F&A) and other related processing services, Knowledge Services, Human Resource Management (HRM), Procurement BPM etc.

Human Resources Processing - HR processing services includes services that support the core HR activities plus talent management activities and associated business processes such as benefits, payroll and talent management.

Knowledge Services - Business research, Market research, Data management & reporting, Data analytics, Social media research, risk management.

The IT department will update the list as and when necessary.

ANNEXURE–V: List of Admissible Items for Fixed Capital

Sl. No.	Items Description
1	Servers with OS
2	Software and Hardware per license cost for BPO/Call Centre Business operations
3	Networking Equipment (Switches, Routers, Firewalls, Voice/Video Conferencing Gateways)
4	Workstations (Desktops, Laptop, Tablets, IP phones, Headsets)
5	Data Storage
6	Structured Cabling
7	UPS
8	Printer, Copier, Scanner & Projector
9	Refrigerator & Water Purifier
10	Fire & Security Items
11	Computer Furniture
12	Electrical wiring & Fittings
13	Central Air-conditioning equipment, air-conditioning System
14	Captive Diesel Generating Set and transformer of capacity commensurate with the actual requirement of the unit, solar power/ Non- conventional Energy Generation Set (OPTIONAL)
15	Fax Machine
16	Private automatic branch exchange
17	Data Communication Equipment, Modem & VSA
18	Other misc. goods not exceeding 5% of the total cost of above items including Tools, kits and spares





ADVANTAGE ASSAM

India's expressway to ASEAN



Information Technology Department
Block-C, 2nd Floor, Janata Bhawan, Dispur,
Guwahati-781 006, Assam (INDIA)
Phone: +91-361-223 7239/ 40
Email: it@assam.gov.in, itdassam@gmail.com

Managing Director,
Assam Electronics Development Corporation Ltd (AMTRON),
Bamunimaidan Industrial Estate, Guwahati-781 021, Assam (INDIA)
Phone: +91-361-265 0111
Email: md@amtron.in